

**NL IT FR DE**
**INSTRUCTIES VOOR HET UITPAKKEN • ISTRUZIONI DI DISIMBALLAGGIO • INSTRUCTIONS DE DEBALLAGE • ANLEITUNG ZUM AUSPAKKEN**

**Verwarmingsrek - 1**  
Griglia scaldavivande - 1  
Grille de réchauffage - 1  
Warmhalterost - 1

**Bedieningspaneel - 1**  
Pannello di controllo - 1  
Console de contrôle gaz - 1  
Bedienfeld - 1

**Rechter framepaneel - 1**  
Telaio destro - 1  
Châssis droit - 1  
Seitenwand rechts - 1

**Linker framepaneel - 1**  
Telaio sinistro - 1  
Châssis gauche - 1  
Seitenwand links - 1

**Linker werkblad - 1**  
Ripiano laterale sinistro - 1  
Plan de travail gauche - 1  
Seitliche Ablage links - 1

**Windvanger - 1**  
Frangivento - 1  
Déflecteur d'air - 1  
Windschutz - 1

**Steun achterframe - 1**  
Traverso telaio posteriore - 1  
Support de châssis arrière - 1  
Hintere Rahmenstrebe - 1

**Steun voorframe - 1**  
Traverso telaio anteriore - 1  
Support de châssis avant - 1  
Vordere Rahmenstrebe - 1

**Onderpaneel - 1**  
Piano inferiore - 1  
Étagère inférieure - 1  
Bodenblech - 1

**Achterpaneel - 1**  
Pannello posteriore - 1  
Panneau arrière - 1  
Rückwand - 1

**Ketel - 1**  
Gruppo fusione forno - 1  
Cuve - 1  
Grillkammer - 1

**Deksel - 1**  
Gruppo coperchio - 1  
Couvercle - 1  
Deckel - 1

**Zijbrander - 1**  
Gruppo fornello laterale - 1  
Réchaud latéral - 1  
Seitenbrenner - 1  
Herausnehmbare

**Uitschuifbare vetopvanglade - 1**  
Vassoio raccogligrassi estraibile - 1  
Bac à graisse coulissant - 1  
Fettauffangschale - 1

**Zwenkwiel voorzien van een rem - 2**  
Ruota piroettante con freno - 2  
Roulette avec frein - 2  
Lenkrolle mit Stoppfunktion - 2

**Zwenkwiel - 2**  
Ruota piroettante - 2  
Roulette - 2  
Lenkrolle - 2

**Houder van opvangpan - 1**  
Supporto leccarda - 1  
Support de bac de récupération - 1  
Halter für Fettfangschale - 1

**Hitteschild - 2**  
Dissipatore di calore - 2  
Réflecteur de chaleur - 2  
Hitzereflektor - 2

**Opvangpan - 1**  
Vaschetta portaleccarda - 1  
Bac de récupération - 1  
Fettfangschale - 1

**Wegwerpdruippan - 1**  
Leccarda monouso - 1  
Barquette en aluminium jetable - 1  
Alu-Tropfschale - 1

**Regelknop - 3**  
Manopola di controllo - 3  
Bouton de réglage gaz - 3  
Bedienknopf - 3

**Sear Station® knop - 1**  
Manopola Sear Station® - 1  
Bouton Sear Station® - 1  
Sear Station®-Bedienknopf - 1

**Handgreep van deur - 2**  
Maniglia - 2  
Poignée de porte - 2  
Türgriff - 2

**Linker deur - 1**  
Anta porta sinistra - 1  
Porte gauche - 1  
Tür links - 1

**Rechter deur - 1**  
Anta porta destra - 1  
Porte droite - 1  
Tür rechts - 1

**Luciferhouder - 1**  
Portafiammiferi - 1  
Porte-allumette - 1  
Zündholzhalter - 1

**Grillrooster - 2**  
Griglia di cottura - 2  
Grille de cuisson - 2  
Grillrost - 2

**Flavorizer® staaf - 5**  
Barra aromatizzante Flavorizer® - 5  
Barre Flavorizer® - 5  
Flavorizer® Bars-Aromaschienen - 5

**Rechter zijtafel - 1**  
Ripiano laterale destro - 1  
Plan de travail droite - 1  
Seitliche Ablage rechts - 1

**Zijtafel met zijbrander - 1**  
Ripiano fornello laterale - 1  
Support du réchaud latéral - 1  
Ablage Seitenbrenner - 1

**ZAK MET BEVESTIGINGSMATERIAAL • BUSTINA MINUTERIA • PACK VISSERIE • BEFESTIGUNGSTEILE**

**INSTALLATIE-INSTRUCTIES • ISTRUZIONI DI MONTAGGIO • INSTRUCTIONS DE MONTAGE • MONTAGEANLEITUNG**

**VEREIST GEREEDSCHAP:  
STRUMENTI NECESSARI:  
OUTILS NECESSAIRES:  
BENÖTIGTE WERKZEUGE:**

**△ BELANGRIJK VOOR HET GOED UITLIJNEN VAN HET FRAME EN DE DEUREN: PLAATS DE BARBECUE OP EEN VLAKKE EN NIET-HELLENDE ONDERGROND.**

**△ IMPORTANTE: PER ALLINEARE CORRETTAMENTE IL TELAIO E GLI SPORTELLI, ASSEMBLARE IL BARBECUE SU UNA SUPERFICIE PIANA E REGOLARE.**

**△ IMPORTANT: POUR ALIGNER CORRECTEMENT LES PORTES, MONTEZ LE BARBECUE SUR UNE SURFACE PLANE ET NIVELEE.**

**△ WICHTIG: DAMIT SIE DIE RAHMENTEILE UND DIE TÜREN EXAKT AUSRICHTEN KÖNNEN, MÜSSEN SIE DEN GRILL AUF EINER FLACHEN UND EBENEN FLÄCHE MONTIEREN.**



Zwarte zeskantbouten - 6  
Bullone nero a testa esagonale - 6  
Vis hexagonale noire - 6  
Sechskantschraube, schwarz - 6

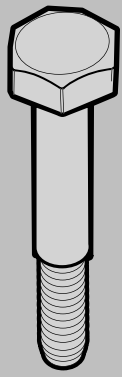

Zeskantbouten - 2  
Bullone argentato a testa esagonale - 2  
Vis hexagonale argentée - 2  
Sechskantschraube, silber - 2

Schroef - 4  
Vite - 4  
Vis - 4  
Schraube - 4

330

Zwarte schroef - 4  
Vite nera - 4  
Vis noire - 4  
Schraube, schwarz - 4

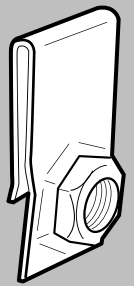

J-klem - 6  
Staffetta a L - 6  
Clip en J - 6  
J-Klammer - 6

Beugel - 4  
Supporto - 4  
Support - 4  
Montageklammer - 4

Zeskantbouten - 12  
Bullone argentato a testa esagonale - 12  
Vis hexagonale argentée - 12  
Sechskantschraube, silber - 12

Schroef - 3  
Vite argentata - 3  
Vis argentée - 3  
Schraube, silber - 3

Zeskantbout - 2  
Bullone argentato a testa esagonale - 2  
Vis hexagonale argentée - 2  
Sechskantschraube, silber - 2

1

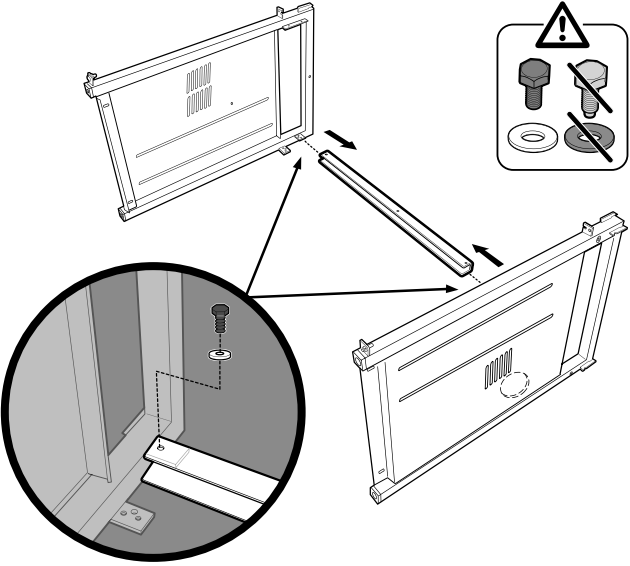
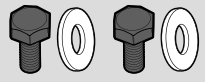

2

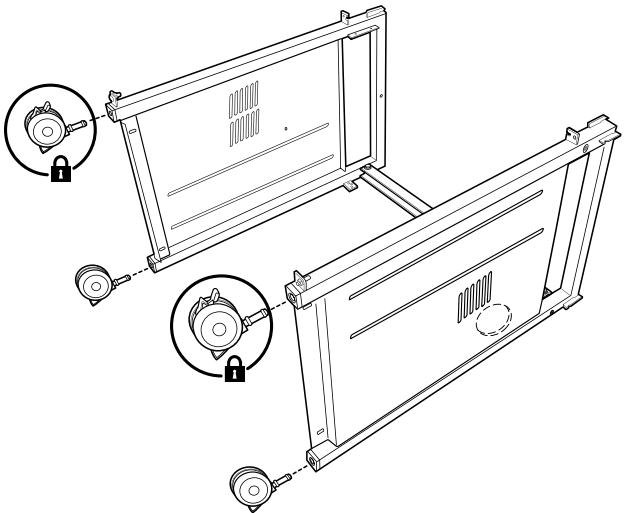
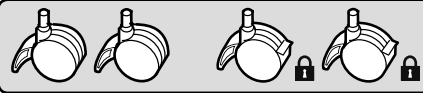

3

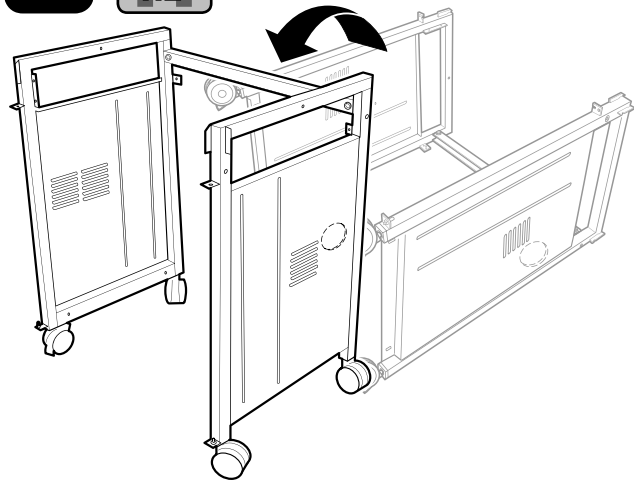

4

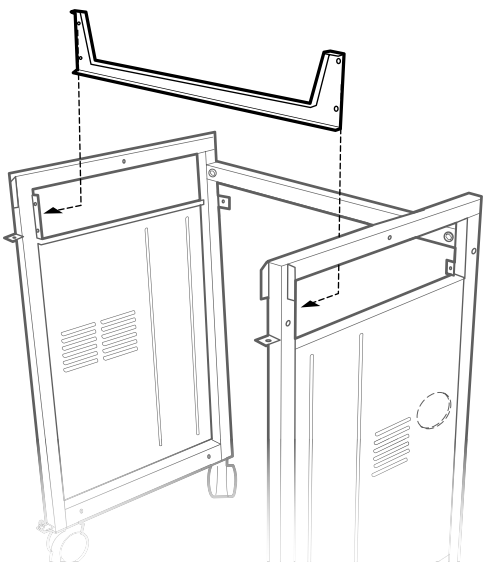

5

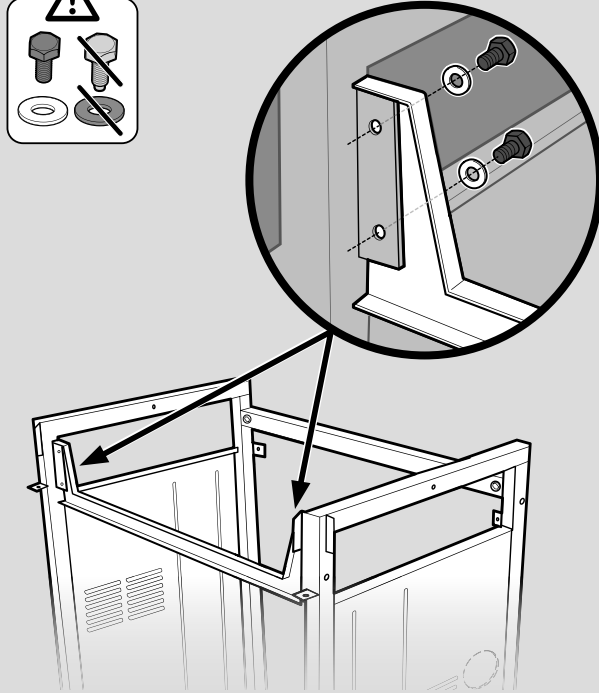
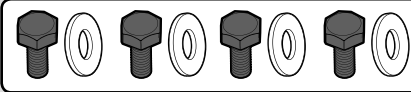

6

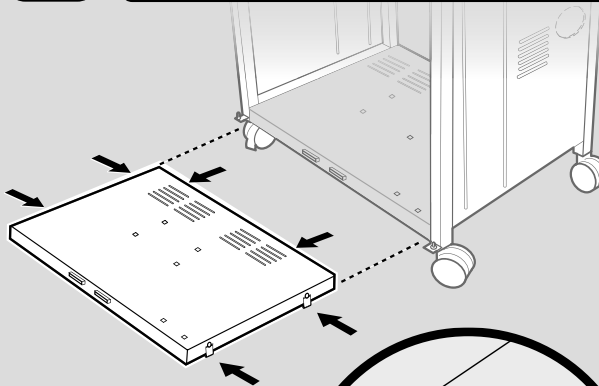
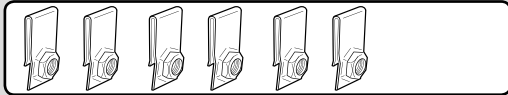

7

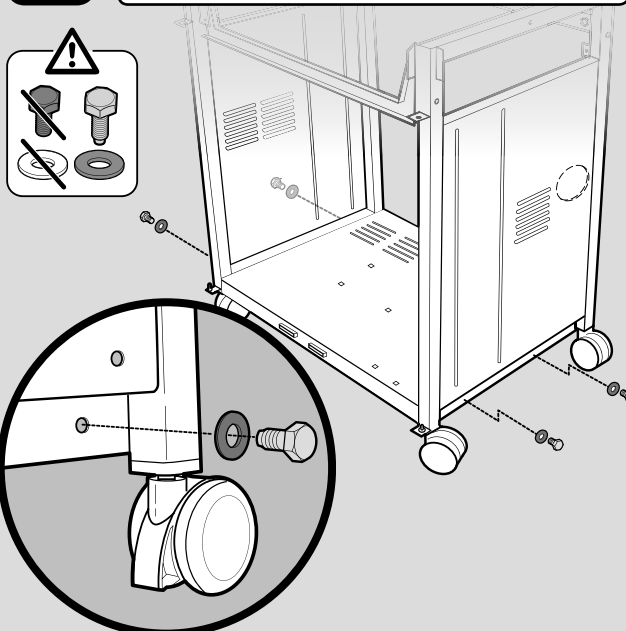
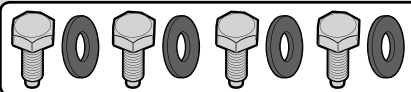

8

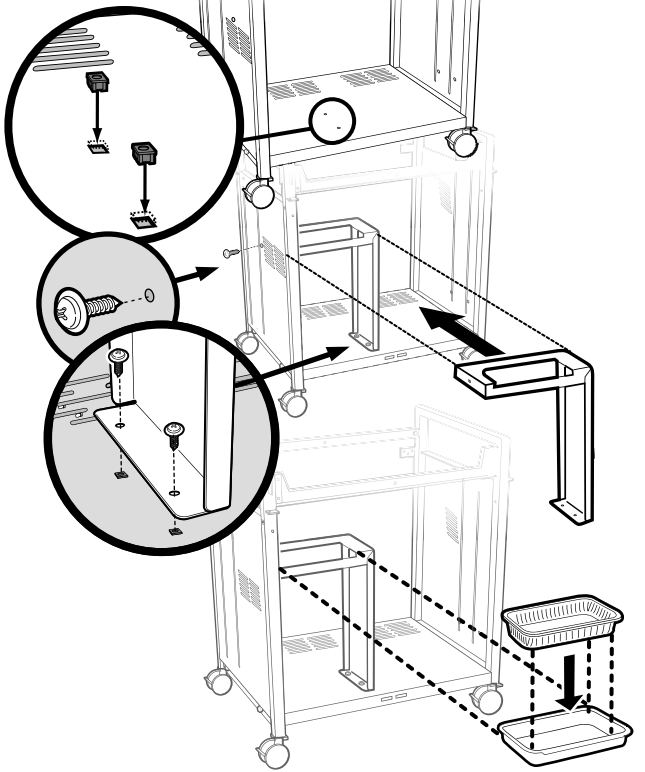

9

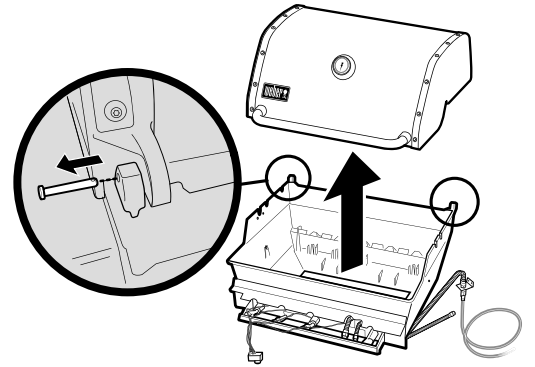

10

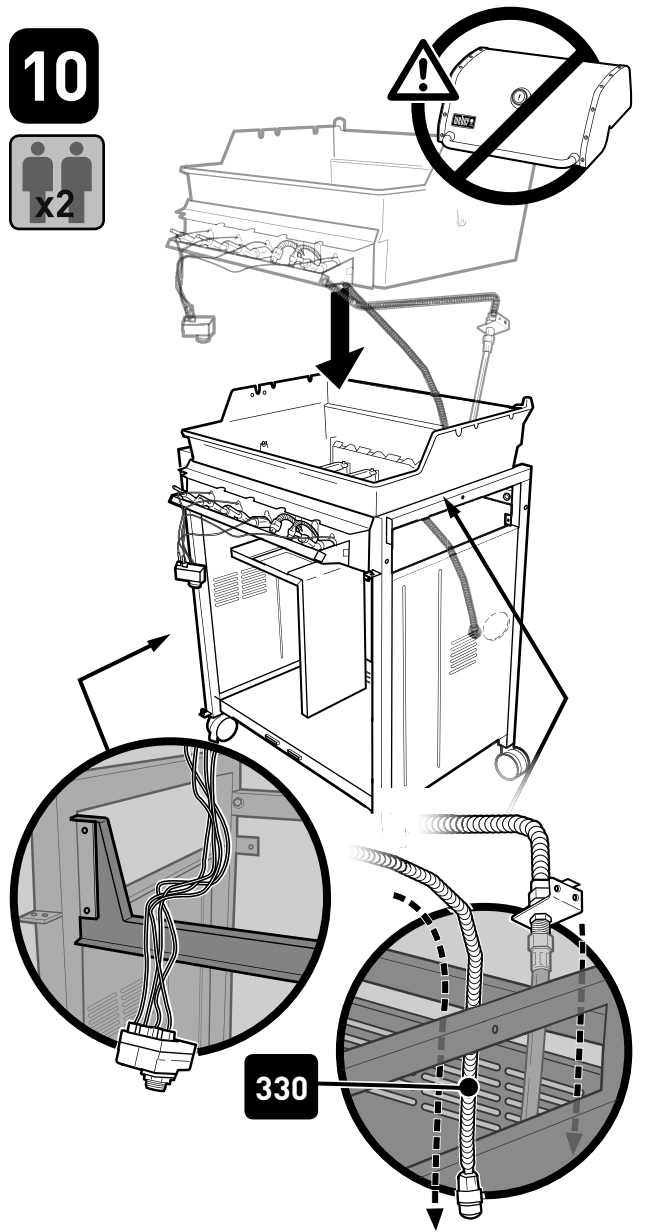



11 mm steeksleutel - 1  
 Chiave 11 mm (7/16 pollice) - 1  
 Clé de montage de 11 mm (7/16 po) - 1  
 Gabelschlüssel 11 mm (7/16 Zoll) - 1



Ring - 8  
 Rondella - 8  
 Rondelle - 8  
 Unterlegscheibe - 8

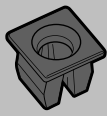

Kunststof plug - 2  
 Tappo in plastica - 2  
 Bouchon en plastique - 2  
 Kunststoffdübel - 2



Ring - 8  
 Rondella argentata - 8  
 Rondelle argentée - 8  
 Unterlegscheibe, silber - 8

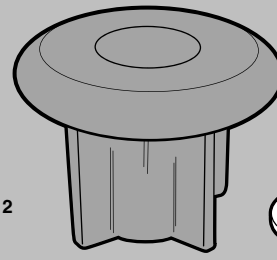

Plug van handgreep - 4  
 Inserto maniglia porta - 4  
 Insert de poignée de porte - 4  
 Gegenstück türgriff - 4



Moer - 2  
 Dado - 2  
 Ecrou - 2  
 Mutter - 2



Kleine ring - 2  
 Rondella piccola - 2  
 Petite rondelle - 2  
 Unterlegscheibe, klein - 2



Splitpen - 2  
 Coppiglia - 2  
 Goupille bêta - 2  
 Splint - 2



Scharnierpen - 2  
 Perno con testa piana - 2  
 Axe d'articulation - 2  
 Bolzen mit Kopf - 2

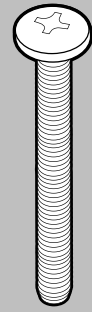

Schroef van handgreep - 4  
 Vite maniglia porta - 4  
 Vis de poignée de porte - 4  
 Schraube türgriff - 4

**11**

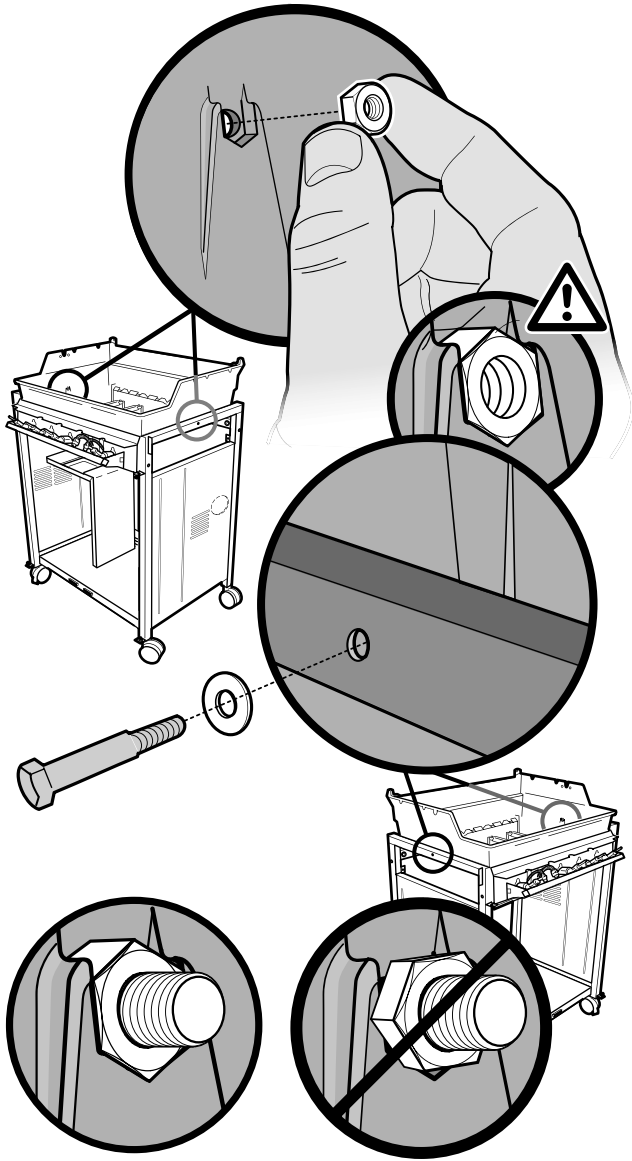
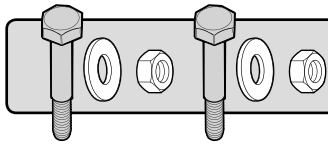

**13**

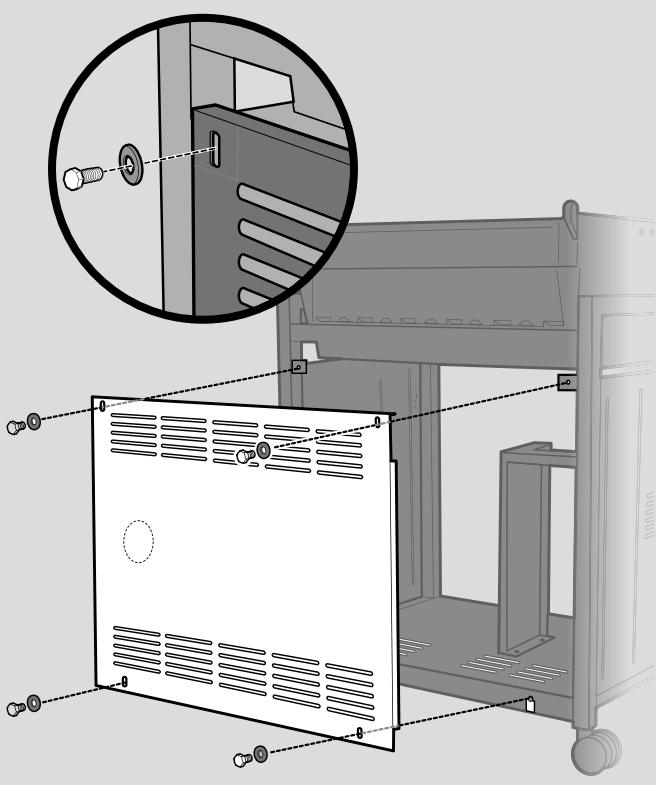
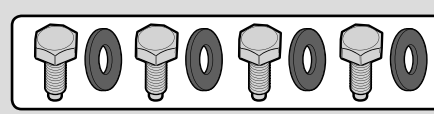

**15**

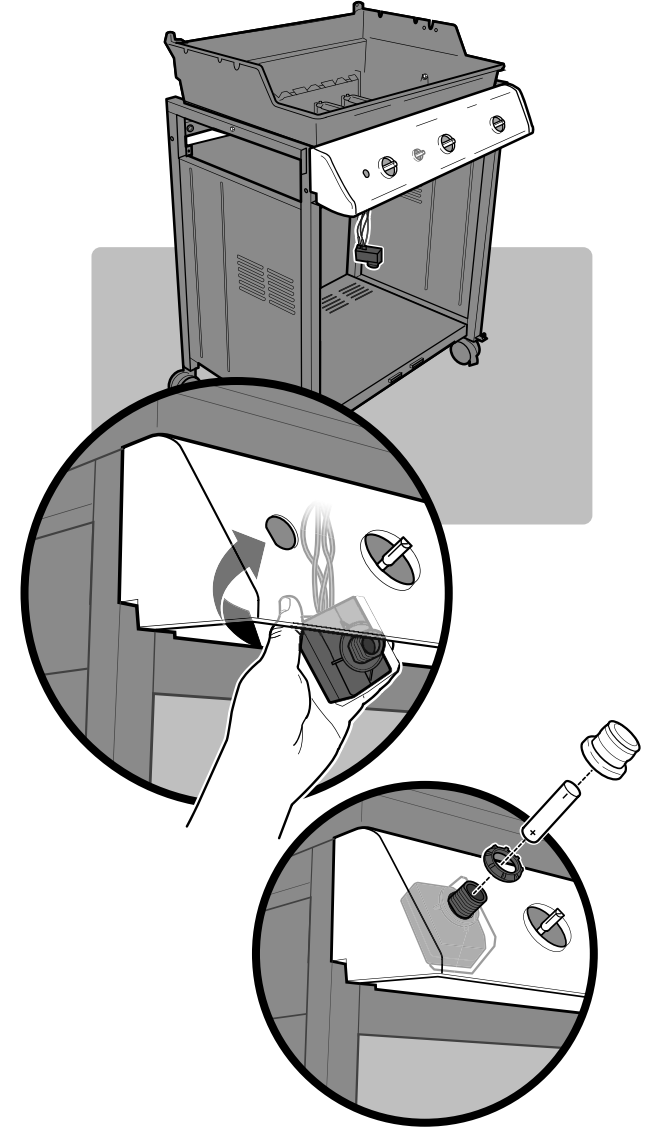
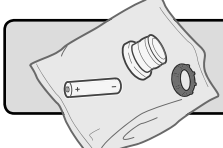

**12**

Kleine ring  
 Rondella piccola  
 Petite rondelle  
 Unterlegscheibe, klein

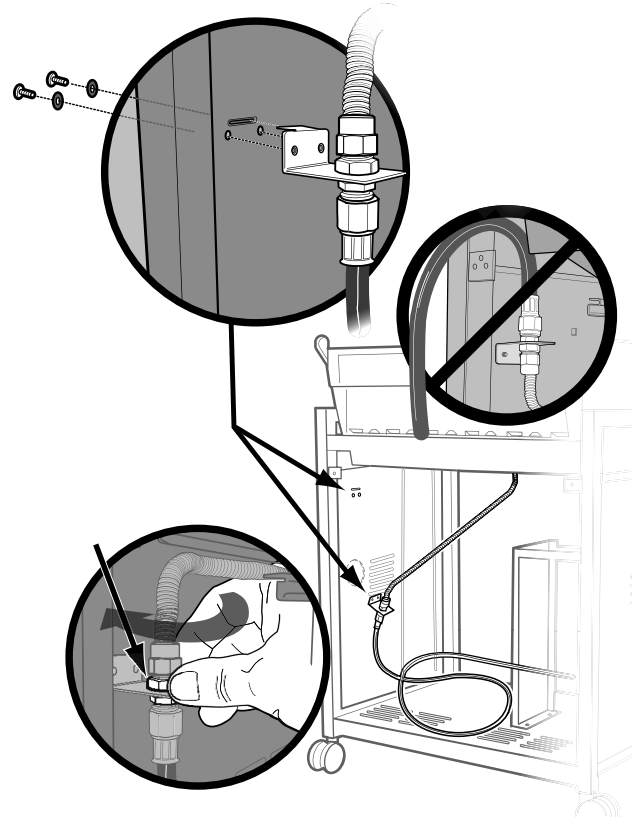

**14**

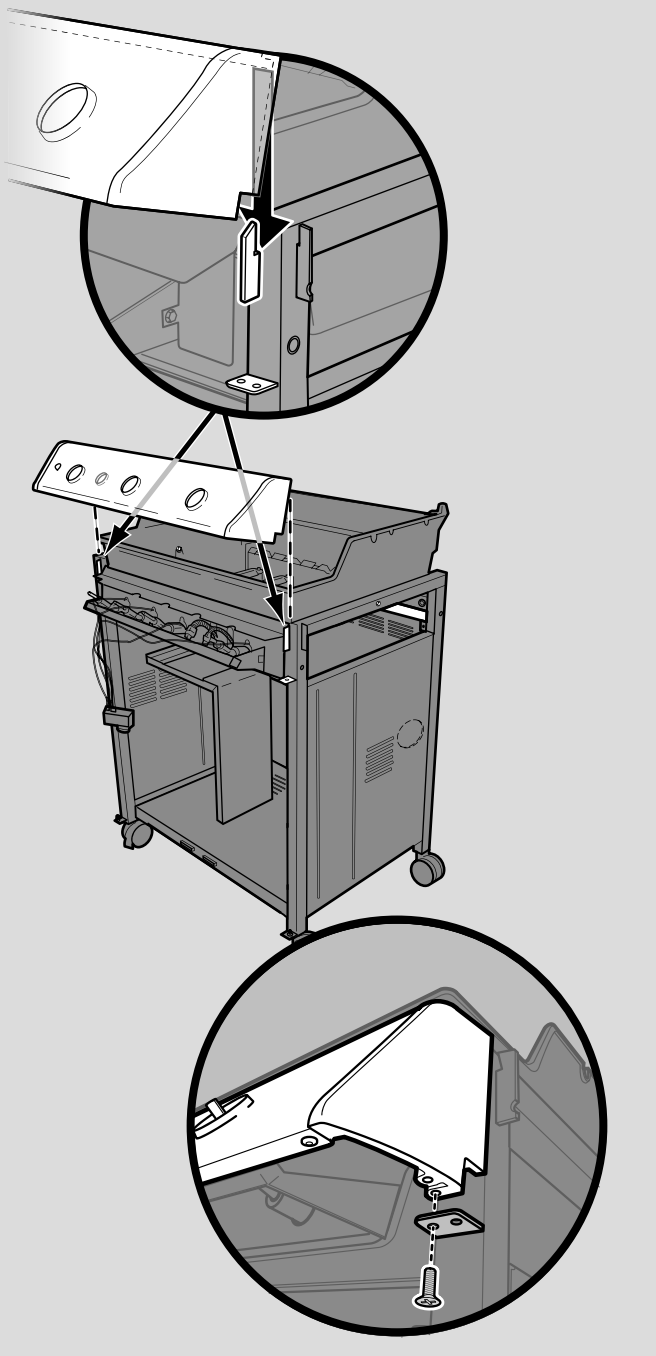

**16**

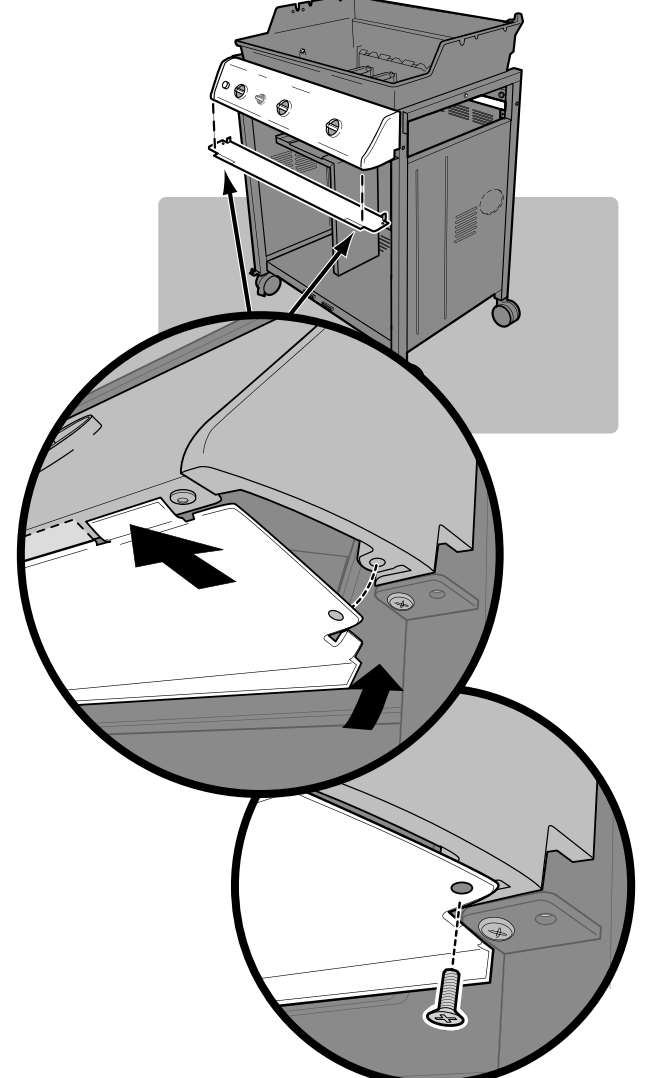
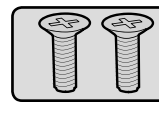

Zie de gebruikershandleiding voor de volledige gasinstructies.  
 Per le istruzioni complete sul collegamento del gas, consultare il Manuale d'uso.  
 Pour obtenir les instructions complètes relatives au gaz, consultez le guide d'utilisation.  
 Weitere Anleitungen zum vollständigen Gasanschluss finden Sie im Bedienerhandbuch.

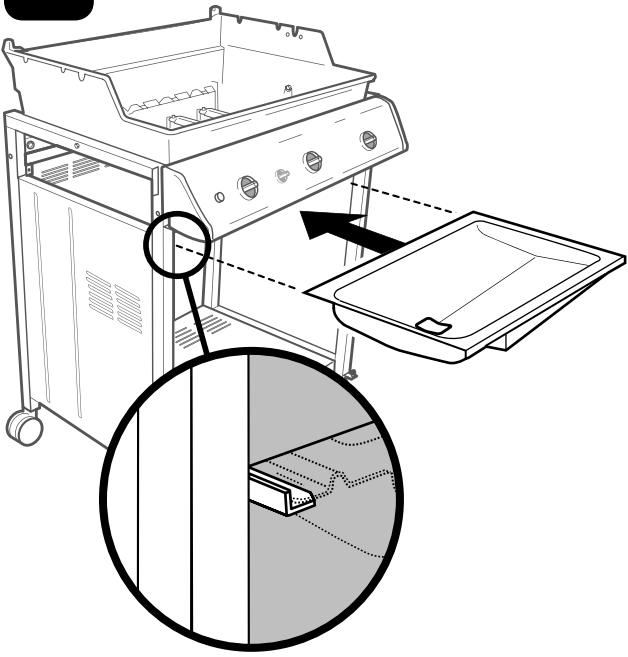
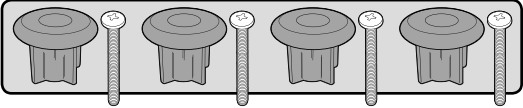
**17****18**

Verwijder voor het installeren van het onderdeel de beschermende folie van het roestvrijstalen onderdeel.  
 Prima di installare il componente, rimuovere la pellicola protettiva dalla parte in acciaio inox.  
 Avant d'installer toutes les pièces, retirez le film protecteur de la partie en acier inoxydable.  
 Entfernen Sie vor der Installation der Komponenten die Schutzfolie von den Edelstahlteilen.

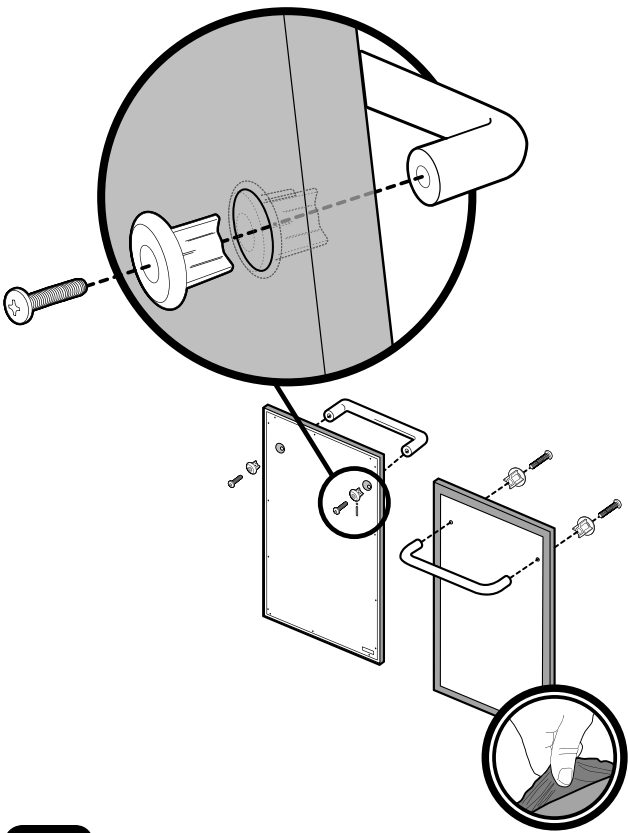
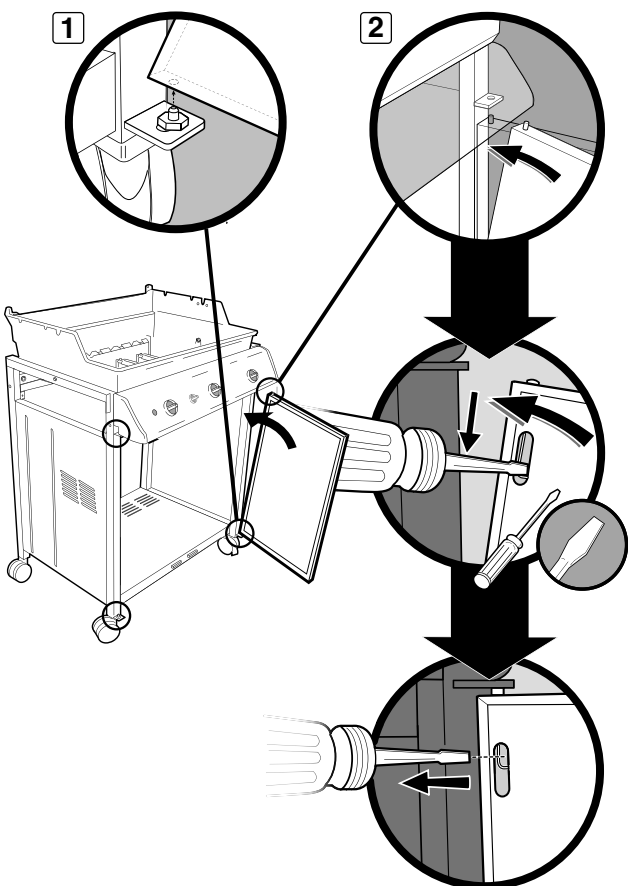
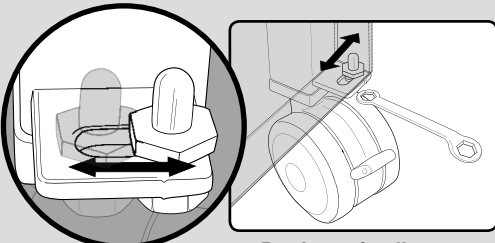
**19****20**

- De deur afstellen
- Per regolare lo sportello
- Réglage de la porte
- So richten Sie die Tür aus

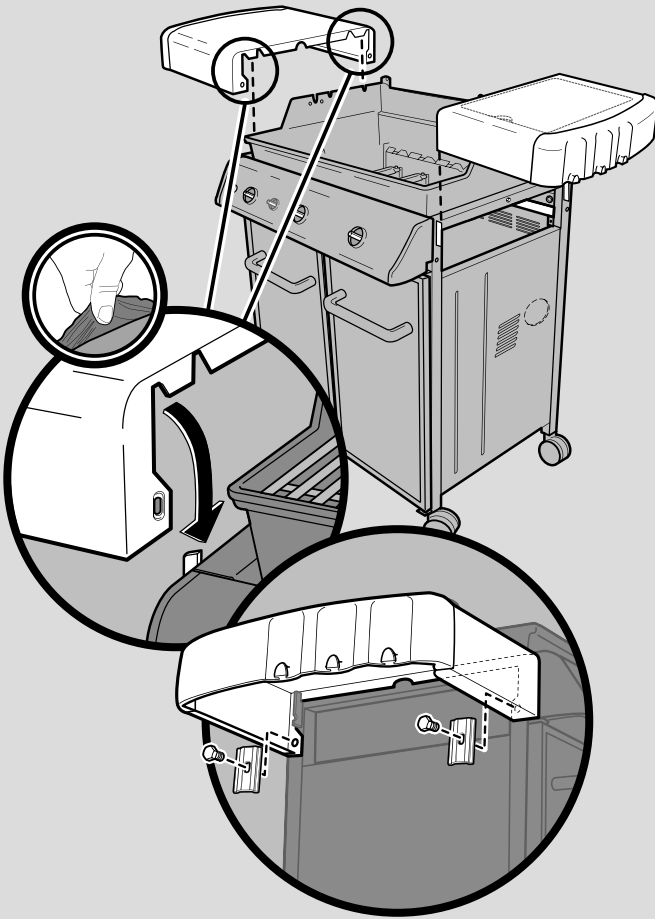
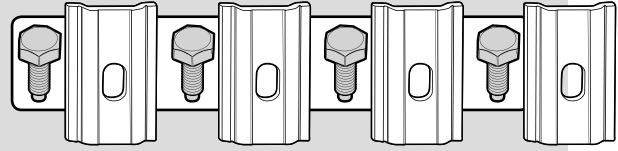
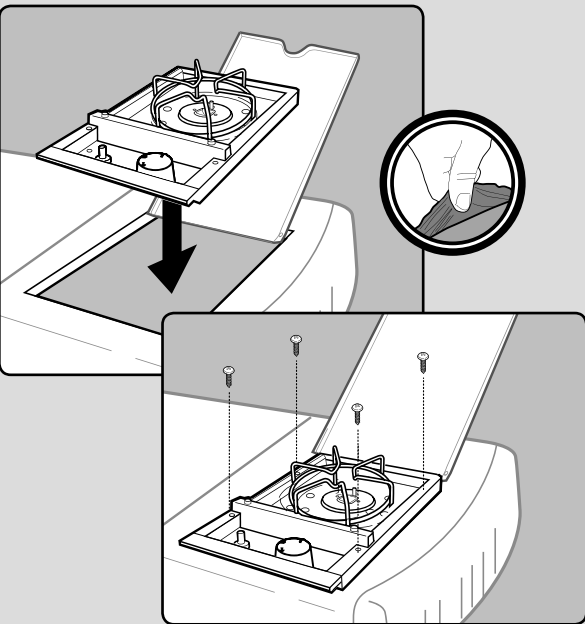
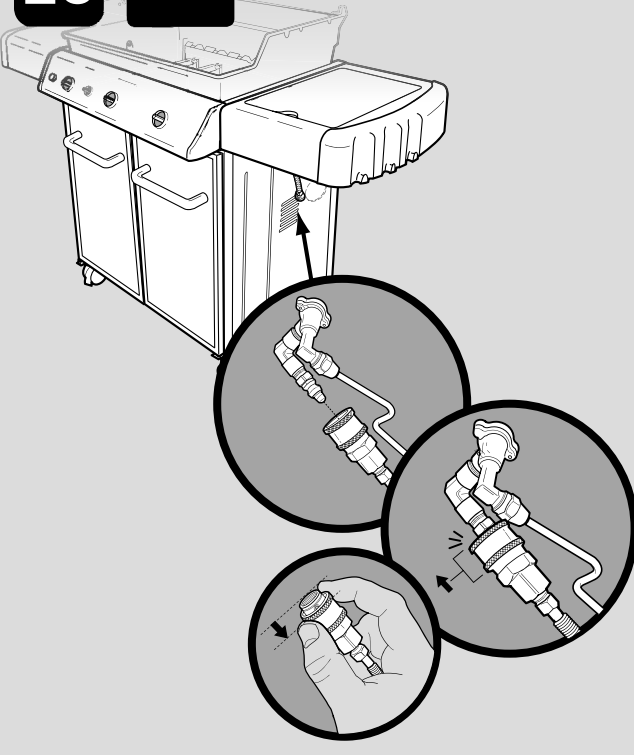
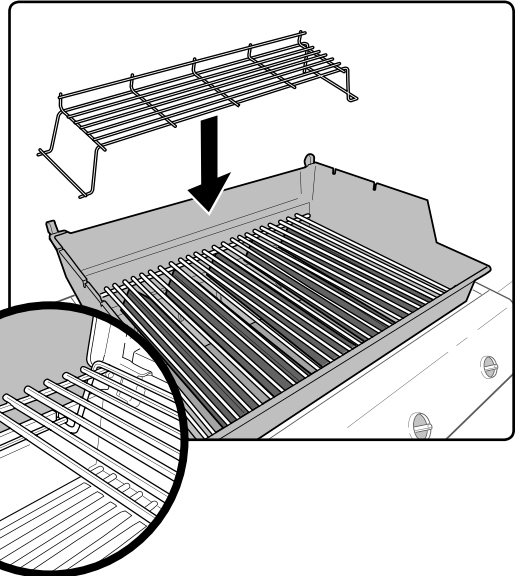
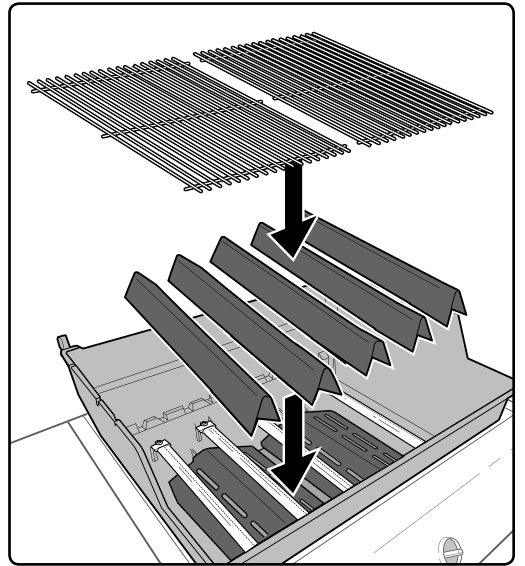
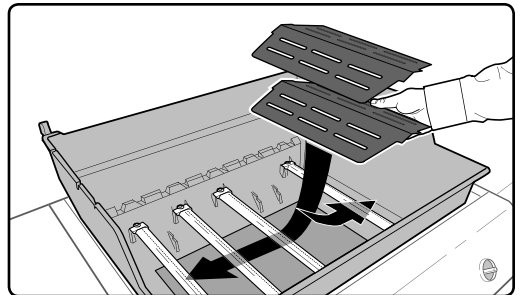
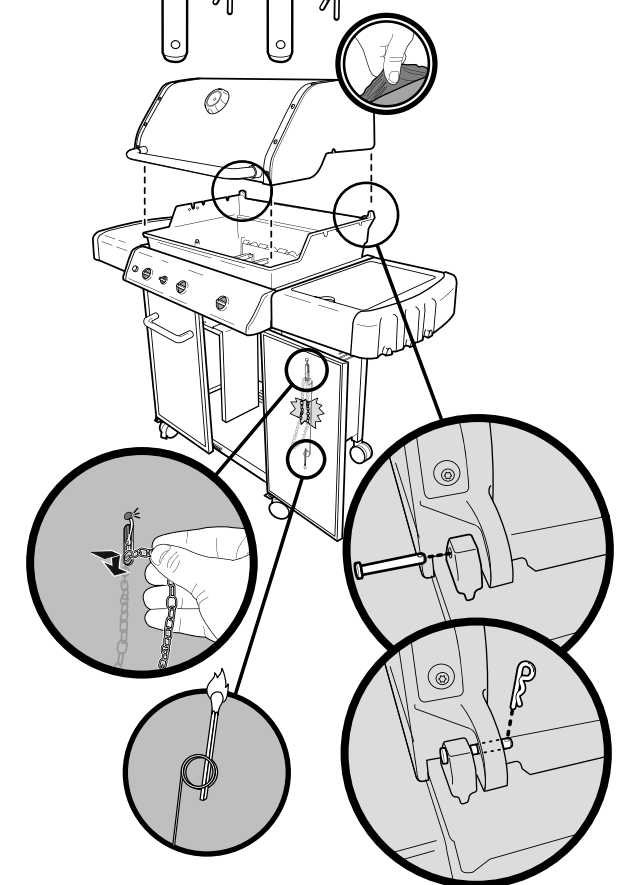
**21****22****330****23****330****24****25****26**